

Semifinal Exam

DO NOT DISTRIBUTE THIS PAGE

Important Instructions for the Exam Supervisor

- This examination consists of two parts.
- Part A has four questions and is allowed 90 minutes.
- Part B has two questions and is allowed 90 minutes.
- The first page that follows is a cover sheet. Examinees may keep the cover sheet for both parts of the exam.
- The parts are then identified by the center header on each page. Examinees are only allowed to do one part at a time, and may not work on other parts, even if they have time remaining.
- Allow 90 minutes to complete Part A. Do not let students look at Part B. Collect the answers to Part A before allowing the examinee to begin Part B. Examinees are allowed a 10 to 15 minute break between parts A and B.
- Allow 90 minutes to complete Part B. Do not let students go back to Part A.
- Ideally the test supervisor will divide the question paper into 3 parts: the cover sheet (page 2), Part A (pages 3-4), and Part B (pages 6-7). Examinees should be provided parts A and B individually, although they may keep the cover sheet.
- The supervisor *must* collect all examination questions, including the cover sheet, at the end of the exam, as well as any scratch paper used by the examinees. Examinees may *not* take the exam questions. The examination questions may be returned to the students after April 1, 2012.
- Examinees are allowed calculators, but they may not use symbolic math, programming, or graphic features of these calculators. Calculators may not be shared and their memory must be cleared of data and programs. Cell phones, PDA's or cameras may not be used during the exam or while the exam papers are present. Examinees may not use any tables, books, or collections of formulas.
- **Please provide the examinees with graph paper for Part A.**

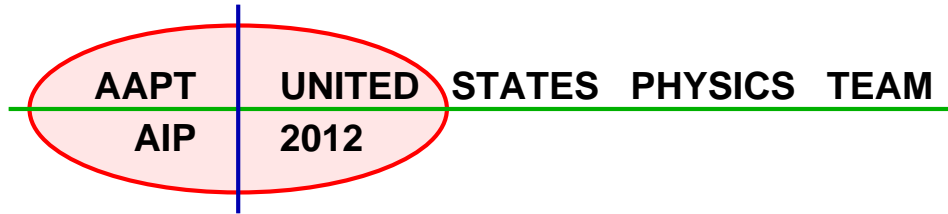

Semifinal Exam

INSTRUCTIONS

DO NOT OPEN THIS TEST UNTIL YOU ARE TOLD TO BEGIN

- Work Part A first. You have 90 minutes to complete all four problems. Each question is worth 25 points. Do not look at Part B during this time.
- After you have completed Part A you may take a break.
- Then work Part B. You have 90 minutes to complete both problems. Each question is worth 50 points. Do not look at Part A during this time.
- Show all your work. Partial credit will be given. Do not write on the back of any page. Do not write anything that you wish graded on the question sheets.
- Start each question on a new sheet of paper. Put your AAPT ID number, your name, the question number and the page number/total pages for this problem, in the upper right hand corner of each page. For example,

AAPT ID #

Doe, Jamie

A1 - 1/3

- A hand-held calculator may be used. Its memory must be cleared of data and programs. You may use only the basic functions found on a simple scientific calculator. Calculators may not be shared. Cell phones, PDA's or cameras may not be used during the exam or while the exam papers are present. You may not use any tables, books, or collections of formulas.
- Questions with the same point value are not necessarily of the same difficulty.
- **In order to maintain exam security, do not communicate any information about the questions (or their answers/solutions) on this contest until after April 1, 2012.**

Possibly Useful Information. You may use this sheet for both parts of the exam.

$$g = 9.8 \text{ N/kg}$$

$$k = 1/4\pi\epsilon_0 = 8.99 \times 10^9 \text{ N} \cdot \text{m}^2/\text{C}^2$$

$$c = 3.00 \times 10^8 \text{ m/s}$$

$$N_A = 6.02 \times 10^{23} \text{ (mol)}^{-1}$$

$$\sigma = 5.67 \times 10^{-8} \text{ J}/(\text{s} \cdot \text{m}^2 \cdot \text{K}^4)$$

$$1\text{eV} = 1.602 \times 10^{-19} \text{ J}$$

$$m_e = 9.109 \times 10^{-31} \text{ kg} = 0.511 \text{ MeV}/c^2$$

$$\sin \theta \approx \theta - \frac{1}{6}\theta^3 \text{ for } |\theta| \ll 1$$

$$G = 6.67 \times 10^{-11} \text{ N} \cdot \text{m}^2/\text{kg}^2$$

$$k_m = \mu_0/4\pi = 10^{-7} \text{ T} \cdot \text{m/A}$$

$$k_B = 1.38 \times 10^{-23} \text{ J/K}$$

$$R = N_A k_B = 8.31 \text{ J}/(\text{mol} \cdot \text{K})$$

$$e = 1.602 \times 10^{-19} \text{ C}$$

$$h = 6.63 \times 10^{-34} \text{ J} \cdot \text{s} = 4.14 \times 10^{-15} \text{ eV} \cdot \text{s}$$

$$(1+x)^n \approx 1+nx \text{ for } |x| \ll 1$$

$$\cos \theta \approx 1 - \frac{1}{2}\theta^2 \text{ for } |\theta| \ll 1$$

Part A

Question A1

A newly discovered subatomic particle, the *S meson*, has a mass M . When at rest, it lives for exactly $\tau = 3 \times 10^{-8}$ seconds before decaying into two identical particles called *P mesons* (peons?) that each have a mass of αM .

- a. In a reference frame where the S meson is at rest, determine
 - i. the kinetic energy,
 - ii. the momentum, and
 - iii. the velocity
 of each P meson particle in terms of M , α , the speed of light c , and any numerical constants.
- b. In a reference frame where the S meson travels 9 meters between creation and decay, determine
 - i. the velocity and
 - ii. kinetic energy of the S meson.

Write the answers in terms of M , the speed of light c , and any numerical constants.

Question A2

An ideal (but not necessarily perfect monatomic) gas undergoes the following cycle.

- The gas starts at pressure P_0 , volume V_0 and temperature T_0 .
- The gas is heated at constant volume to a pressure αP_0 , where $\alpha > 1$.
- The gas is then allowed to expand adiabatically (no heat is transferred to or from the gas) to pressure P_0
- The gas is cooled at constant pressure back to the original state.

The adiabatic constant γ is defined in terms of the specific heat at constant pressure C_p and the specific heat at constant volume C_v by the ratio $\gamma = C_p/C_v$.

- a. Determine the efficiency of this cycle in terms of α and the adiabatic constant γ . As a reminder, efficiency is defined as the ratio of work out divided by heat in.
- b. A lab worker makes measurements of the temperature and pressure of the gas during the adiabatic process. The results, in terms of T_0 and P_0 are

Pressure	units of P_0	1.21	1.41	1.59	1.73	2.14
Temperature	units of T_0	2.11	2.21	2.28	2.34	2.49

Plot an appropriate graph from this data that can be used to determine the adiabatic constant.

- c. What is γ for this gas?

Question A3

This problem inspired by the 2008 Guangdong Province Physics Olympiad

Two infinitely long concentric hollow cylinders have radii a and $4a$. Both cylinders are insulators; the inner cylinder has a uniformly distributed charge per length of $+\lambda$; the outer cylinder has a uniformly distributed charge per length of $-\lambda$.

An infinitely long dielectric cylinder with permittivity $\epsilon = \kappa\epsilon_0$, where κ is the dielectric constant, has a inner radius $2a$ and outer radius $3a$ is also concentric with the insulating cylinders. The dielectric cylinder is rotating about its axis with an angular velocity $\omega \ll c/a$, where c is the speed of light. Assume that the permeability of the dielectric cylinder and the space between the cylinders is that of free space, μ_0 .

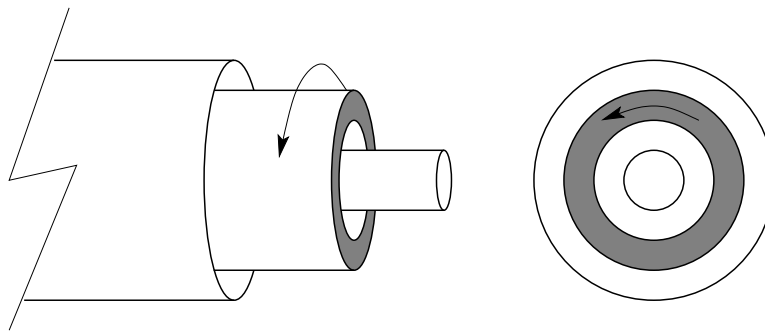

- Determine the electric field for all regions.
- Determine the magnetic field for all regions.

Question A4

Two masses m separated by a distance l are given initial velocities v_0 as shown in the diagram. The masses interact only through universal gravitation.

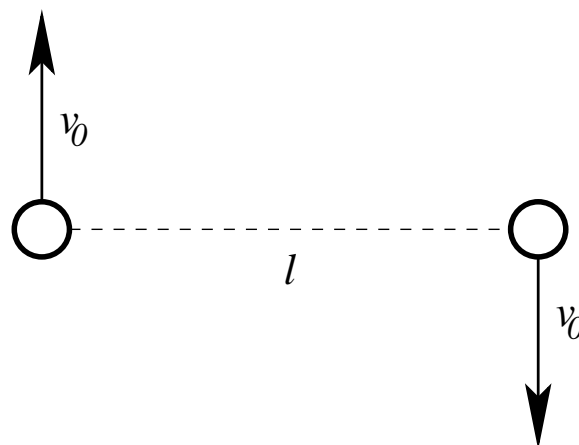

- Under what conditions will the masses eventually collide?
- Under what conditions will the masses follow circular orbits of diameter l ?
- Under what conditions will the masses follow closed orbits?
- What is the minimum distance achieved between the masses along their path?

STOP: Do Not Continue to Part B

If there is still time remaining for Part A, you should review your work for Part A, but do not continue to Part B until instructed by your exam supervisor.

Part B

Question B1

A particle of mass m moves under a force similar to that of an ideal spring, except that the force repels the particle from the origin:

$$F = +m\alpha^2 x$$

In simple harmonic motion, the position of the particle as a function of time can be written

$$x(t) = A \cos \omega t + B \sin \omega t$$

Likewise, in the present case we have

$$x(t) = A f_1(t) + B f_2(t)$$

for some appropriate functions f_1 and f_2 .

- $f_1(t)$ and $f_2(t)$ can be chosen to have the form e^{rt} . What are the two appropriate values of r ?
- Suppose that the particle begins at position $x(0) = x_0$ and with velocity $v(0) = 0$. What is $x(t)$?
- A second, identical particle begins at position $x(0) = 0$ with velocity $v(0) = v_0$. The second particle becomes closer and closer to the first particle as time goes on. What is v_0 ?

Question B2

For this problem, assume the existence of a hypothetical particle known as a *magnetic monopole*. Such a particle would have a “magnetic charge” q_m , and in analogy to an electrically charged particle would produce a radially directed magnetic field of magnitude

$$B = \frac{\mu_0 q_m}{4\pi r^2}$$

and be subject to a force (in the absence of electric fields)

$$F = q_m B$$

A magnetic monopole of mass m and magnetic charge q_m is constrained to move on a vertical, nonmagnetic, insulating, frictionless U-shaped track. At the bottom of the track is a wire loop whose radius b is much smaller than the width of the “U” of the track. The section of track near the loop can thus be approximated as a long straight line. The wire that makes up the loop has radius $a \ll b$ and resistivity ρ . The monopole is released from rest a height H above the bottom of the track.

Ignore the self-inductance of the loop, and assume that the monopole passes through the loop many times before coming to a rest.

- Suppose the monopole is a distance x from the center of the loop. What is the magnetic flux ϕ_B through the loop?
- Suppose in addition that the monopole is traveling at a velocity v . What is the emf \mathcal{E} in the loop?
- Find the change in speed Δv of the monopole on one trip through the loop.
- How many times does the monopole pass through the loop before coming to a rest?
- Alternate Approach:** You may, instead, opt to find the above answers to within a dimensionless multiplicative constant (like $\frac{2}{3}$ or π^2). If you only do this approach, you will be able to earn up to 60% of the possible score for each part of this question.

You might want to make use of the integral

$$\int_{-\infty}^{\infty} \frac{1}{(1+u^2)^3} du = \frac{3\pi}{8}$$

or the integral

$$\int_0^{\pi} \sin^4 \theta d\theta = \frac{3\pi}{8}$$